

Paramount

Model # EF-WM410 &
EF-WM411
Item #W914-36F &
W914-48FT

USE AND CARE GUIDE

ELECTRIC FIREPLACE INSTRUCTION MANUAL



Questions, problems, missing parts? Before returning to the store, please contact customer service at customercare@jrhome.com or call 1-800-561-5550 7 a.m. - 4 p.m., PST, Monday – Friday

1-800-561-5550

WWW.JRHOME.COM



THANK YOU

We appreciate the trust and confidence you have placed in Paramount through the purchase of this Outdoor Heater. We strive to continually create quality products designed to enhance your home. Visit us online to see our full line of products available for your home improvement needs. Thank you for choosing Paramount!

Table of Contents

Table of Contents	2	Installation	4-8
Safety Information	2	Wall mount.....	4-7
Pre-Installation	3	Free Standing (Stand Brackets).....	8
Planning Installation	3	Installing Media (Step 6 & 7)	6-8
Electrical Parameters		Operation.....	9-10
Package/Hardware List	3	Maintenance, Care & Cleaning	10
Package Contents	3	Troubleshooting	11
		Warranty.....	11-12

IMPORTANT SAFETY INSTRUCTIONS

SAVE THESE INSTRUCTIONS FOR FUTURE USE

WHEN USING ELECTRICAL APPLIANCES, BASIC PRECAUTIONS SHOULD ALWAYS BE FOLLOWED TO REDUCE THE RISK OF FIRE, ELECTRIC SHOCK, AND INJURY TO PERSONS, INCLUDING THE FOLLOWING:

Read all instructions before using this heater. Failure to follow these important safety instructions may cause fire, electric shock or damage. Following proper safety and operating instructions is the responsibility of the owner.

1. Grounding (If necessary) - this heater is for use on 120 volts. DO NOT attempt to modify the plug in any way or use adaptors to defeat the purpose of the grounding feature.
2. This heater is hot when in use. To avoid burns, do not let skin come in direct contact with hot surfaces. The grill directly in front of the heater outlet becomes hot during heater operation.
3. **CAUTION:** Extreme caution is necessary when any heater is used by or near children or those with disabilities. Never leave the heater operating unattended.
4. Do not operate any heater with a damaged cord or plug or after the heater malfunctions, has been dropped or damaged in any manner. Take heater to authorized service facility for examination, electrical or mechanical adjustment or repair.
5. Under no circumstance should this electric heater be modified. Parts having to be removed for servicing must be replaced by a certified repair center prior to operating this electric heater again.
6. Do not use outdoors or anywhere it can get wet. This heater is not intended for use in bathrooms, laundry areas and similar indoor locations. Never locate heater where it may fall into a bathtub or in the vicinity of water.
7. Do not run cord under carpeting. Do not cover cord with throw rugs, runners, or similar coverings. Arrange cord away from traffic area and where it will not be tripped over.
8. To disconnect heater, turn off all controls, then remove plug from outlet.
9. Connect to property grounded outlets only.
10. Do not insert or allow foreign objects to enter any ventilation or exhaust opening as this may cause an electric shock or fire, or damage the heater.
11. To prevent a possible fire, do not block air intakes or exhaust

in any manner. Do not use on soft surfaces, like a bed, where openings may become blocked.

12. **CAUTION:** A heater has hot and arcing or sparking parts inside. Do not use it in areas where gasoline, propane, paint, or flammable liquids are used or stored or where the unit will be exposed to flammable vapors. The heater should not be used as a drying rack for clothing. Do not hand any decorations on the heater.
13. Do not modify this heater. Use this heater only as described in this manual. Any other use not recommended by the manufacturer may cause fire, electric shock, or injury to persons.
14. Avoid the use of an extension cord because the extension cord may overheat and cause a risk of fire. However, if you have to use an extension cord, the cord shall be No.16AWG minimum size and rated not less than 1875 watts, and 3-wire cord with grounding type plug and cord connector.
15. Do not plug this product into a receptacle controlled by a wall switch or dimmer.
16. Always use a certified electrician should new circuits or outlets be required.
17. Always disconnect power before performing any cleaning, maintenance or relocation of the heater.
18. For off-season storage, keep in a dry place, free from excessive vibration damage.

NOTE: Procedures and techniques that are considered important enough to emphasize.

CAUTION: Procedures and techniques, which, if not carefully followed, will result in damage to the equipment or personal property or may cause personal injury.

WARNING: Procedures and techniques, which, if not carefully followed, will expose the user to the risk of serious injury, illness or death.

WARNING:

This heater and parts become hot when in use. The area directly around and under the heater must be clear and free of any obstructions.

DO NOT ALLOW CHILDREN TO OPERATE THIS HEATER. KEEP CHILDREN AND PETS AWAY FROM HEATER AND CONTROLS

Pre-Installation-Package and Hardware Contents

PLANNING INSTALLATION

Before beginning assembly, be sure to empty contents of carton and make sure all parts are present. Place all parts on a soft, level surface for assembly. If any parts are missing, please contact Customer Service between 8 a.m. - 7 p.m., EST, Monday – Friday, 9 a.m. – 6 p.m., EST, Saturday.

Estimated Assembly Time: Varies depending upon type .

A Phillips head screwdriver or Electric Drill with Phillips Head Bit is required for installation. (not included)

ELECTRICAL PARAMETER

- Power supply: 120V AC
- Frequency: 60Hz
- Power: 1500W

 **WARNING:** If the supply cord is damaged, it must be replaced by the manufacturer, its service agent or similarly qualified persons in order to avoid a hazard..

 **NOTE:** Hardware not shown to actual size.

PACKAGE/HARDWARE CONTENTS

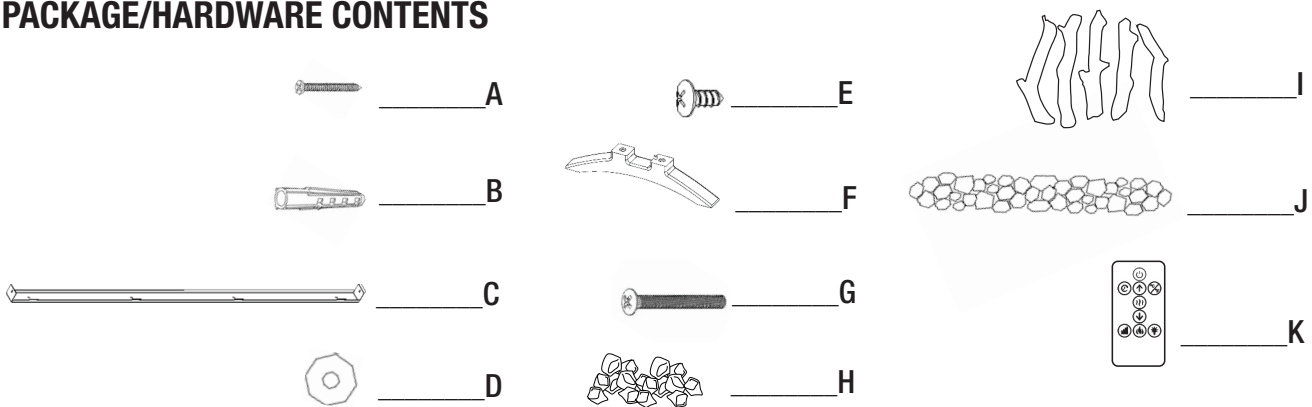

Part	Description	Quantity
A	Anchor Screw	4
B	Drywall Anchor	4
C	Bracket	1
D	Washer	4
E	Small Screw	3
F	Stand Bracket	2
G	Bolt	4
H	Crystals	1 Bag
I	Decorative Logs (36")	6
	Decorative Logs (48")	9
J	Stones	1 Bag
K	Remote Control	1

Installation- Wall Mount

1 Wall location preparation

- Select the wall location where you want to hang your fireplace.
- Draw a horizontal line using a level (Figure F)
- Using the mounting bracket as a guide, mark 4 drill holes for the 4 anchors (for drywall) or 4 screws (for wood studs).

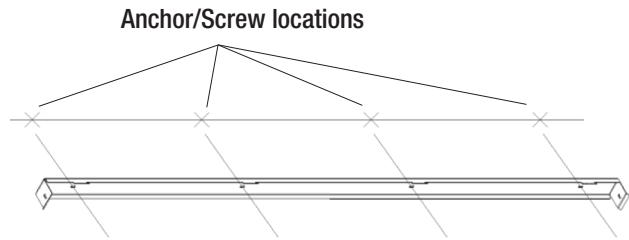

Figure F



NOTE: The holes are for mounting the fireplace. Insure the horizontal line is level so the heater can be mounted properly.



NOTE: Please maintain at least 36 inches between the air outlet on the fireplace and the ceiling.

2 Pre-drill screw

- Drill 4 holes 8 mm (5/16in) in diameter and 43 mm (1.7in) deep on the marked locations.
- For holes that do not hit a stud, use the supplied wall anchor. Install the wall anchors into the holes and gently tap them into place with a hammer until the flange of the wall anchor is flush with the wall surface. See Figure G.



B X 4 (or as required)

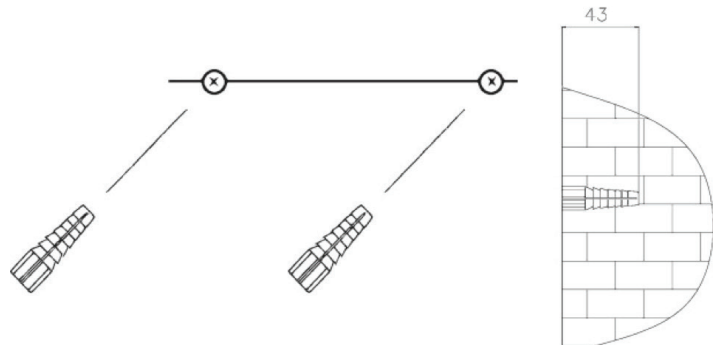



Figure G

Installation- Wall Mount (continued)

3 Attach the bracket

- Secure the mounting bracket to the wall anchors using the 4 anchor screws and 4 washers as shown in Figure H

 _____ A X 4

 _____ D X 4

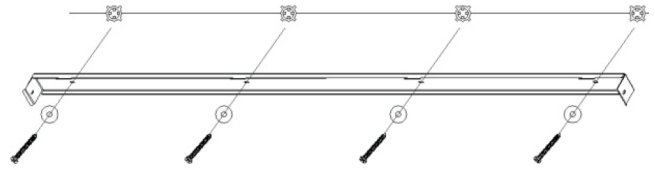

Figure H

4 Mounting the fireplace

- Mount the fireplace on the wall using the keyhole slots of the metal bracket at the back of the heater. See Figure I
- Make sure that the mounting bracket is completely engaged into the metal bracket at the back of the heater.

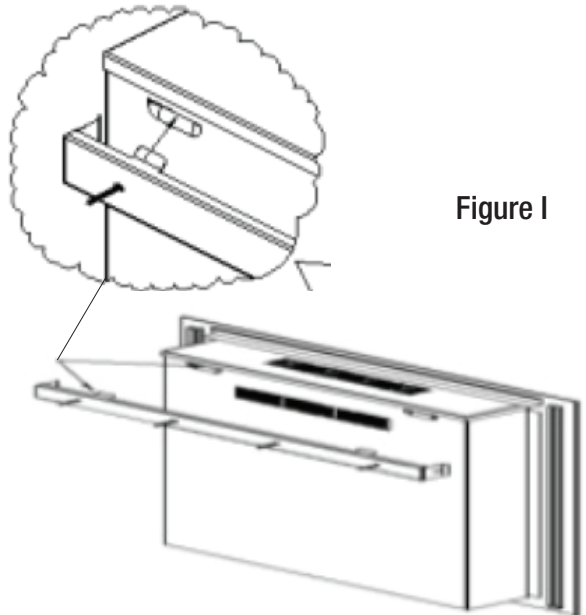

Figure I

Installation- Wall Mount (continued)

5 Secure mounting bracket

- Secure the mounting bracket to the heater using 2 mounting screws. See Figure J.

 E X 2

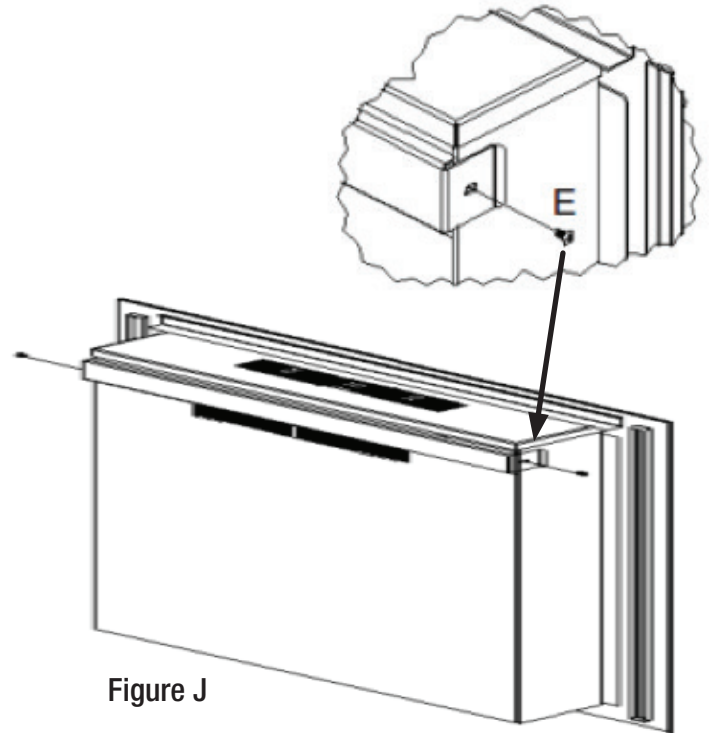

6 Remove the front cover

- Remove the two fastening screws.
- Remove the front cover by pulling it outward (See Figure A)

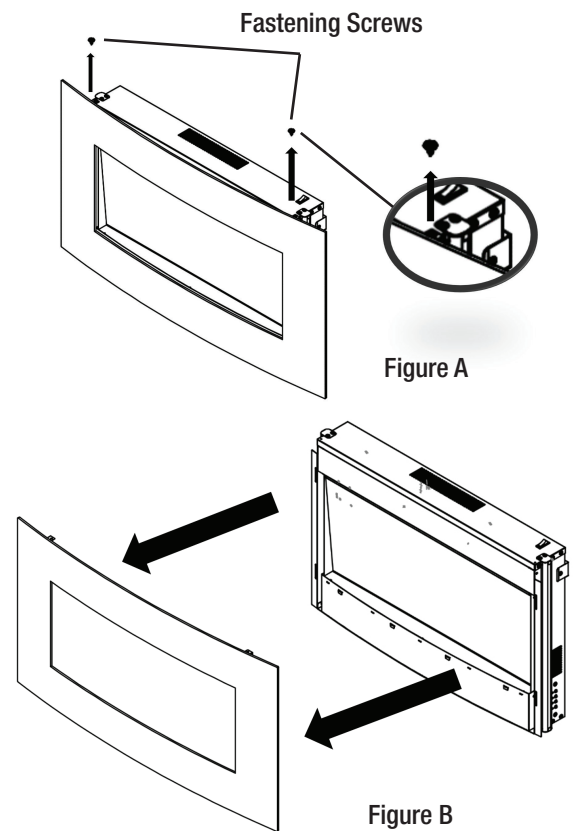

Installation- Wall Mount (continued)

7 Place Decorative Media

- Put the decorative log, stones & crystals into the heater. (Figure 1)
- Media may be combined or displayed individually.



NOTE: This Step applies for all installations.

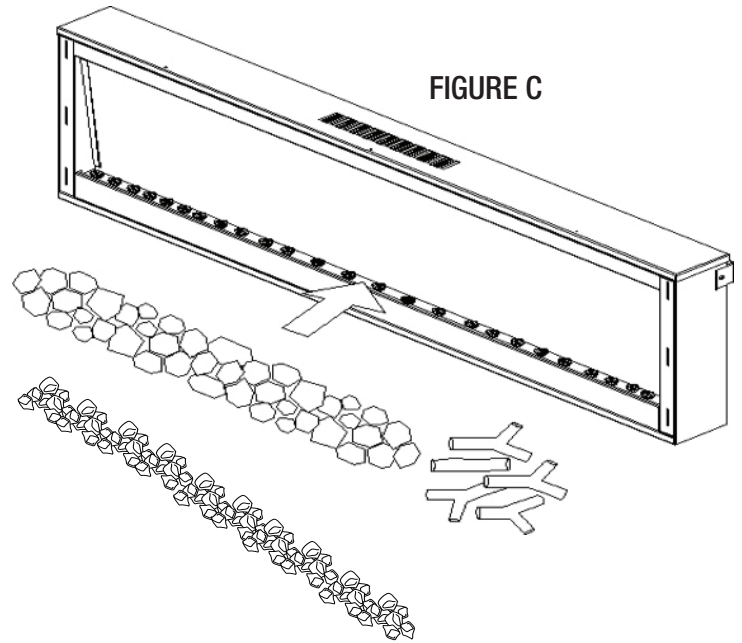
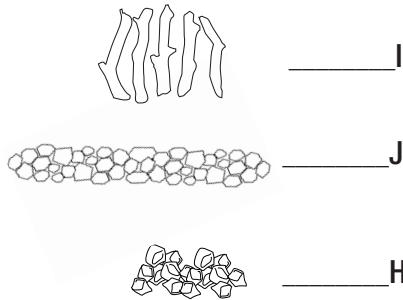

8 Replace the front cover

- Replace the front cover moving it back into place (Figure D)
- Reattach the two fastening screws. (See Figure E)

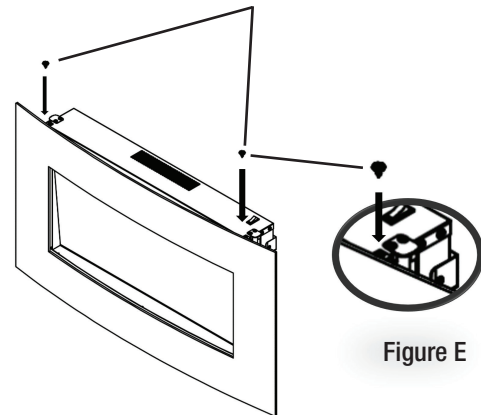
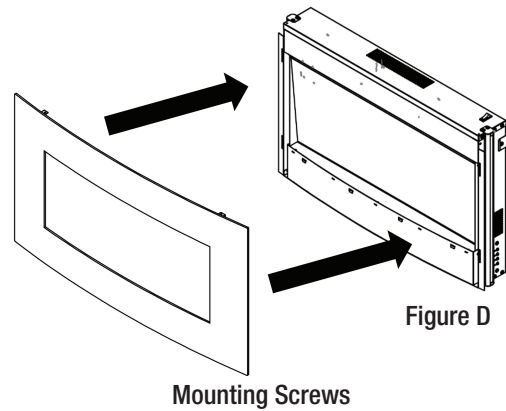

Installation- Stand Brackets

1 Attach stands

- Fix the bracket by installing four G screws (See Fig. L)

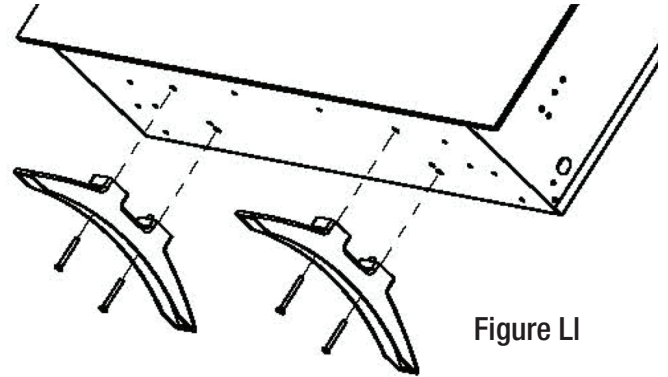
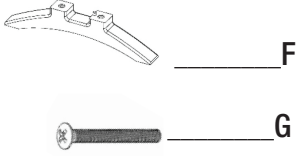

Figure LI

Operation

1 Pre-Operation







CAUTION: Do not attempt to operate this appliance until you have read and understand all Safety Information in this manual and all assembly is complete and leak tests have been performed.

After reading all the instructions, make sure that all the fireplace controls are in the OFF position. Plug the fireplace into a 15A/120V outlet.

2 Operating Fireplace Controls

The controls are located at the right of the heater outlet.



	<p>Press this button to turn ON the fireplace. Press again to turn off the fireplace and the fan will continue to work for 60 seconds without heat.</p>
	<p>Press this button to change the flame effect. By default, the flame color is yellow.</p> <p>Press again to change flame color. There are ten groups of flame colors including four primary colors: yellow, blue, green and red and six different combinations of mixed primary colors.</p> <p>Hold the button 3 seconds and longer, the background light will turn on and change its colors : Blue, green, red ,purple, yellow ,white and cyan. Long press to change one color at a time.</p>
	<p>Press this button to change flame intensity. Press again to decrease the flame intensity. There are 6 light intensities for your selection. The flame optics will go lower under the sequence of 6,5,4,3,2 and 1.</p> <p>Pressing the button again will stop the flame effect.</p>
	<p>Press this button to set the desired temperature.</p> <p>When desired ambient temperature is reached, the heater will automatically stop heating.</p> <p>When the ambient temperature drops below the desired temperature 2°C, the heater will resume heating.</p>

3 Operation By Remote Control

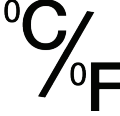
	<p>Press this button to turn ON the fireplace and the fan will continue to work for 60 seconds without heat.</p>	
	<p>Press this button for timer function. The letters '0H' to '8H' will appear on the LED screen. '0H' means there is no set running time and heater will run continuously. The letters '1H' to '8H' mean the number of hours that the heater will operate before shutting off.</p>	
	<p>Press this button to toggle between the two temperature scales. The corresponding Celsius (C) or Fahrenheit (F) LED indicates the current setting.</p>	
	<p>For heat function - Press this button to turn on the heat function. Press again to turn off.</p>	
	<p>Press this button to change flame intensity. Press again to decrease the flame intensity. There are 6 light intensities for your selection. The flame optics will go lower under the sequence of 6,5,4,3,2 and 1.</p> <p>Pressing the button again will stop the flame effect.</p>	
	<p>Press this button to change flame effect. The unit will beep. By default, the flame color is yellow. Press again to change flame color. There are ten groups of flame colors. Including four primary colors: yellow, blue, green and red and six different combinations of mixed colors.</p>	
	<p>Press to change backlight effect. There are seven types of backlight effect, consisting of blue, green, red, purple, yellow, white and cyan. Press this button until the desired color is set.</p>	
	<p>Press up or down button to the desired temperature. When desired ambient temperature is reached, the heater will automatically stop heating. When the ambient temperature drops below the desired temperature 2°C, the heater will resume heating.</p>	

Operation - (continued)

4 Operation with The DEMO Switch



Press the I/O switch to turn on/turn off the power for heating system. When the switch is turned off, you still can control the flame and background light, but the power for heating system. If you want to open the heating function, pls make sure the switch is turned on.

5 Remote Control Battery Replacement:

- Replace with a CR2025 battery and follow the diagram at the back of remote handset to install the new battery.

Maintenance, Care & Cleaning

1 Maintenance:

- **WARNING:** Completely disconnect power before attempting any maintenance or cleaning, to reduce the risk of fire or electric shock. Maintenance should only be performed by a certified technician.

2 Cleaning:

- Before cleaning any parts of the fireplace make sure to first turn off the controls and then unplug the unit from power source.
- **CAUTION:** Wait until the unit has completely cooled before attempting any cleaning.
- **Cleaning Glass Panel:** Remove dust with clean dry cloth. Remove fingerprints and other marks from glass door by using a clean damp cloth. Do not use abrasive cleaners or spray liquids on glass door surfaces.
- Metal and metal painted parts should be cleaned with clean damp cloth only. Do not use abrasive cleaners or spray liquids on these surfaces.

3 Anti-frost function

- The fireplace has anti-frost function.
- When the room temperature is below 32°F/0°C the start-up time will be delayed by several minutes

Troubleshooting

PROBLEM	POSSIBLE CAUSE	CORRECTIVE ACTION
Fireplace doesn't work.	Fireplace inner components are overheating or the home circuit breaker has tripped.	Reset switch by turning master switch off and waiting for 5mins, then turning it back on.
Flame is not moving.	Wiring may be loose or the flame motor may be defective	Call customer service for instructions.
Dim or poorly visible flame or crystals aren't glowing.	LED lights are burnt out or the wiring is loose.	Call customer service for instructions.
Flame sputters.	Flame motor is defective.	Call customer service for instructions.
Remote control does not work.	Low battery. Master switch is in "OFF" position.	Change the battery for remote control. Check to make sure the master switch is turned on.
Circuit breaker trips or fuse blows when the unit is on.	Improper circuit current rating.	Turn off electrical equipment sharing the circuit. Call customer service for instructions.
Heater does not provide heat when turned on.	Thermal switch has been tripped. Circuit breaker has been tripped.	Turn the unit off and unplug the unit for 5mins. Plug back in and turn on the unit. Turn off circuit breaker that supplies electricity to the unit, wait 5 minutes, then flip circuit breaker back on
Appliance turns off and will not turn on.	Appliance has overheated and its safety device has caused the thermal switch to disconnect. House circuit breaker has tripped	Unplug the appliance, allow to cool for 15mins, then plug back in. Reset the house circuit breaker.

Review & Warranty Extension



Extend Your Warranty By Leaving A Review

We want your opinion about your purchase...and we want you to tell everyone about it! Just leave a review for the product on the retailers website where you made your purchase, or at www.jrhome.com, and fill in the online warranty at <https://www.jrhome.com/warranty-registration> to receive a complimentary extra year of warranty protection.

Follow us on:



www.jrhome.com #paramount

Warranty

For questions, concerns or problems with our product please email our customer service department:

customercare@jrhome.com

DATED PROOF OF PURCHASE REQUIRED FOR WARRANTY SERVICE

WARRANTY

This product is inspected, tested and carefully packaged to minimize the chance of damage during shipment. If a part (excluding light bulbs, glass and fuses*) within one year from the date of purchase proves to be defective in material or fabrication under normal use, the part will be repaired or replaced. The Company's obligation under the warranty is to replace or repair defective parts at our discretion. Any expenses or damage resulting from the installation, removal or transportation of the product will be the responsibility of the owner and are not covered by this warranty. The owner assumes all other risks arising from the use or misuse of the product. The warranty will be void if the product damage or failure is deemed by the Company to be caused by accident, alteration, misuse, abuse, incorrect installation or removal, or connection to an incorrect power source by the owner. The Company neither assumes, nor authorizes any person or entity to assume for it any obligation or liability associated with its products. Light bulbs and fuses are not covered under this warranty. If you have any questions regarding the warranty or service, please contact us at **customercare@jrhome.com**.

Customer Service :

JR Home Products

Unit 306 - 19100 Airport Way, Pitt Meadows, BC V3Y 0E2

Toll Free : 1-800-561-5550

E-mail : **customercare@jrhome.com**

You MUST register your product within 30 days of purchase to receive warranty service.

Registration can be completed online at www.jrhome.com or by mailing this form.

Si vous éprouvez des difficultés ou si vous avez des questions ou des préoccupations, prière de faire parvenir un courriel à notre service à la clientèle

customercare@jrhome.com

UNE PREUVE D'ACHAT DATÉE EST REQUISE POUR SE PRÉVALOIR DE LA GARANTIE.

AVERTISSEMENT

Ce produit a été soigneusement inspecté, testé et emballé afin de minimiser les risques de dommages durant le transport. Si l'une des pièces (à l'exception des verres, des ampoules électriques et des fusibles*) s'avère défectueuse au niveau de sa fabrication ou de ses matériaux dans l'année qui suit la date de l'achat suite à une utilisation normale, la pièce sera réparée ou remplacée. La compagnie est tenue de réparer ou remplacer les pièces défectueuses à sa discrétion, en vertu de la garantie. Tous frais ou dommage résultant de l'installation, du démantèlement ou du transport du produit demeurent la responsabilité du client et n'est pas couvert par cette garantie. Le client assume tout autre risque résultant de l'utilisation correcte ou fautive du produit. La garantie devient nulle si la compagnie détermine que le dommage ou le mauvais fonctionnement est causé par un accident, une modification, une mauvaise utilisation, un abus, une mauvaise installation ou un mauvais démantèlement ou un branchement à une source électrique inadéquate de la part du client. La compagnie n'est pas responsable et n'autorise quiconque, personne ou entité légale, à accepter de responsabilité ou obligation en son nom, en rapport avec ses produits. * Les ampoules électriques et les fusibles ne sont pas couverts par cette garantie. Pour toute question au sujet de la garantie ou du service, contacter le service à la clientèle à : **customercare@jrhome.com**.

Service à la clientèle:

JR Home Products

Unit 306 - 19100 Airport Way, Pitt Meadows BC V3Y 0E2 Numéro

sans frais: 1-800-561-5550

Courriel: **customercare@jrhome.com**

Vous DEVEZ enregistrer votre produit dans les 30 jours suivant l'achat pour bénéficier du service de garantie.

L'enregistrement sera complet une fois que vous aurez posté ce formulaire ou que vous serez inscrit en ligne.



Warranty Registration Information Form / Formulaire d'enregistrement de la garantie

Name / Nom : _____

Street / Adresse : _____

City / Ville : _____

Province / Province : _____

Postal Code / Code postal : _____

Daytime Phone # / No téléphone jour : _____

Evening Phone # / No téléphone soir : _____

E-Mail Address / Courriel : _____

Product/Produit : _____

Place of Purchase / Lieu de l'achat : _____

Date of Purchase / Date de l'achat : _____

Model # / No de modèle : _____

Serial # / Numéro de série : _____

You MUST register your product to receive warranty service.

For warranty service, contact J&R Home Products at the address, phone numbers listed below within 30 days of purchase. Be sure to have your sales receipt and original date of purchase. All warranty service will be coordinated by J&R Home Products service center.

Vous DEVEZ enregistrer votre produit pour vous prévaloir de la garantie.

Afin de faire valoir la garantie, communiquez avec J&R Home Products à l'adresse et aux numéros indiqués ci-dessous dans les 30 jours suivant la date d'achat. Ayez en main votre reçu et la date d'achat. Toutes les demandes liées aux garanties seront traitées par le centre de service de J&R Home Products.

Please mail to / Veuillez poster le tout à : Parts & Service Department, J&R Home Products Ltd. Unit 306 - 19100 Airport Way, Pitt Meadows, BC V3Y 0E2

120920

Paramount

Questions, problems, missing parts? Before returning to the store, please contact customer service at customer care@jrhome.com or call 1-800-561-5550 7 a.m. - 4 p.m., PST, Monday – Friday

JRHOME.COM

Retain this manual for future use.